

PART 3



SKYLANE 182T

SPECIFICATION AND DESCRIPTION



JULY 2018

REVISION F
SERIAL NUMBER 182T-83001 TO TBD

SPECIFICATION AND DESCRIPTION



SKYLANE 182T

SERIAL NUMBER 182T-83001 TO TBD

JULY 2018

REVISION F

TABLE OF CONTENTS

LIST OF FIGURES.....	iv
INTRODUCTION.....	1
THE AIRCRAFT.....	2
1. GENERAL DESCRIPTION.....	2
1.1 Certification.....	2
1.2 Purchaser's Responsibility.....	2
1.3 Approximate Dimensions.....	5
1.4 Design Weights and Capacities.....	5
2. PERFORMANCE.....	6
3. DESIGN LIMITS.....	6
4. FUSELAGE.....	7
4.1 Design and Construction.....	7
4.2 Nose Section.....	7
4.3 Interior Spaces.....	7
4.4 Aft Fuselage.....	7
5. WING.....	7
6. EMPENNAGE.....	7
7. LANDING GEAR.....	7
7.1 Design and Construction.....	7
7.2 Nosewheel Steering.....	8
7.3 Brakes and Tires.....	8
8. PROPULSION.....	8
8.1 Powerplant.....	8
8.2 Propeller.....	8
9. SYSTEMS.....	8
9.1 Flight Controls.....	8
9.2 Fuel System.....	9
9.3 Electrical System.....	9
9.4 Exterior Lighting System.....	9
9.4.1 Primary.....	9
9.4.2 Secondary.....	9
9.5 Environmental System.....	9

TABLE OF CONTENTS CONT

10. FLIGHT COMPARTMENT	10
10.1 General.....	10
10.2 Instrumentation	10
10.3 Avionics.....	11
10.3.1 Flight Displays.....	11
10.3.1.1 Primary Flight Display (PFD)	11
10.3.1.2 Multi-Function Display (MFD).....	11
10.3.2 Garmin’s Integrated Avionics Unit (GIA).....	11
10.3.2.1 Global Positioning System (GPS).....	11
10.3.2.2 Very High Frequency Radio (VHF).....	11
10.3.2.3 Navigation Receivers.....	12
10.3.3 Engine Indicating System (EIS).....	12
10.3.4 Crew Alerting System (CAS)	12
10.3.5 Flight Guidance System (FGS)	12
10.3.6 Attitude/Heading Reference System (AHRS)	12
10.3.7 Transponder with ADS-B In/Out Capability	12
10.3.8 Emergency Locator Transmitter (ELT)	12
10.3.9 Standby Instrumentation.....	13
11. INTERIOR	14
11.1 Cabin	14
11.2 Entertainment System	15
11.3 Windows	15
11.4 Interior Lighting System	15
11.5 Interior Storage.....	15
12. EXTERIOR.....	15
13. LOOSE EQUIPMENT	15
14. EMERGENCY EQUIPMENT	16
15. DOCUMENTATION AND TECHNICAL PUBLICATIONS	16
16. LIMITED WARRANTIES.....	17
16.1 Limited Aircraft Warranty	17
16.2 Summary of Seller’s Limited Propeller Warranty	21

TABLE OF CONTENTS CONT

16.3 Summary of Lycoming Engine Warranty	23
17. FAMILIARIZATION TRAINING AGREEMENT	26

LIST OF FIGURES

Figure 1: Exterior Dimensions	3
Figure 2: Interior Dimensions	4
Figure 3: Instrumentation	10
Figure 4: Typical Configuration	15

INTRODUCTION

This Specification and Description provides general information about the design, performance, and standard equipment of the Skylane 182T, Serial Number 182T-83001 to TBD (hereinafter Skylane 182T, Skylane or Aircraft). Due to the lapse of time between the date of this publication and Aircraft delivery, Textron Aviation (hereinafter Seller) reserves the right to revise this Specification and Description when occasioned by product improvements, government regulations, or other good cause, as long as the revisions do not result in a material reduction in Aircraft performance. If there is a conflict between this Specification and Description and the Aircraft Purchase Agreement into which it is incorporated, the terms and conditions of the Aircraft Purchase Agreement control.

For further information contact:

Textron Aviation Contracts
Textron Aviation Inc.
P.O. Box 7706
Wichita, Kansas 67277-7706

Telephone: 316-517-6000
Fax: 316-517-6640
E-Mail: contracts@txtav.com

THE AIRCRAFT

1. GENERAL DESCRIPTION

The Skylane 182T is a single engine high-wing piston aircraft. The Aircraft has provisions for four passengers (four is standard) and is certified for a single pilot. The Skylane 182T has one interior storage compartment for personal items, baggage, and cargo.

One Lycoming IO-540-AB1A5 engine with a McCauley three blade metal constant speed propeller power the Skylane 182T, and a Garmin G1000 NXi system provides pilots with a digital avionics suite.

1.1 Certification

The Skylane 182T is certified in accordance with U.S. FAR Part 23, Normal Category, including day, night, VFR and IFR.

1.2 Purchaser's Responsibility

International aircraft certification may require modifications to and the incorporation of additional equipment into the Aircraft. The Aircraft purchaser (Purchaser) is responsible for the costs of any such modifications and incorporation of additional equipment. In addition, the Purchaser is responsible for obtaining approval to operate the Aircraft from the relevant civil aviation authority and for understanding and complying with applicable crew requirements.

EXTERIOR DIMENSIONS

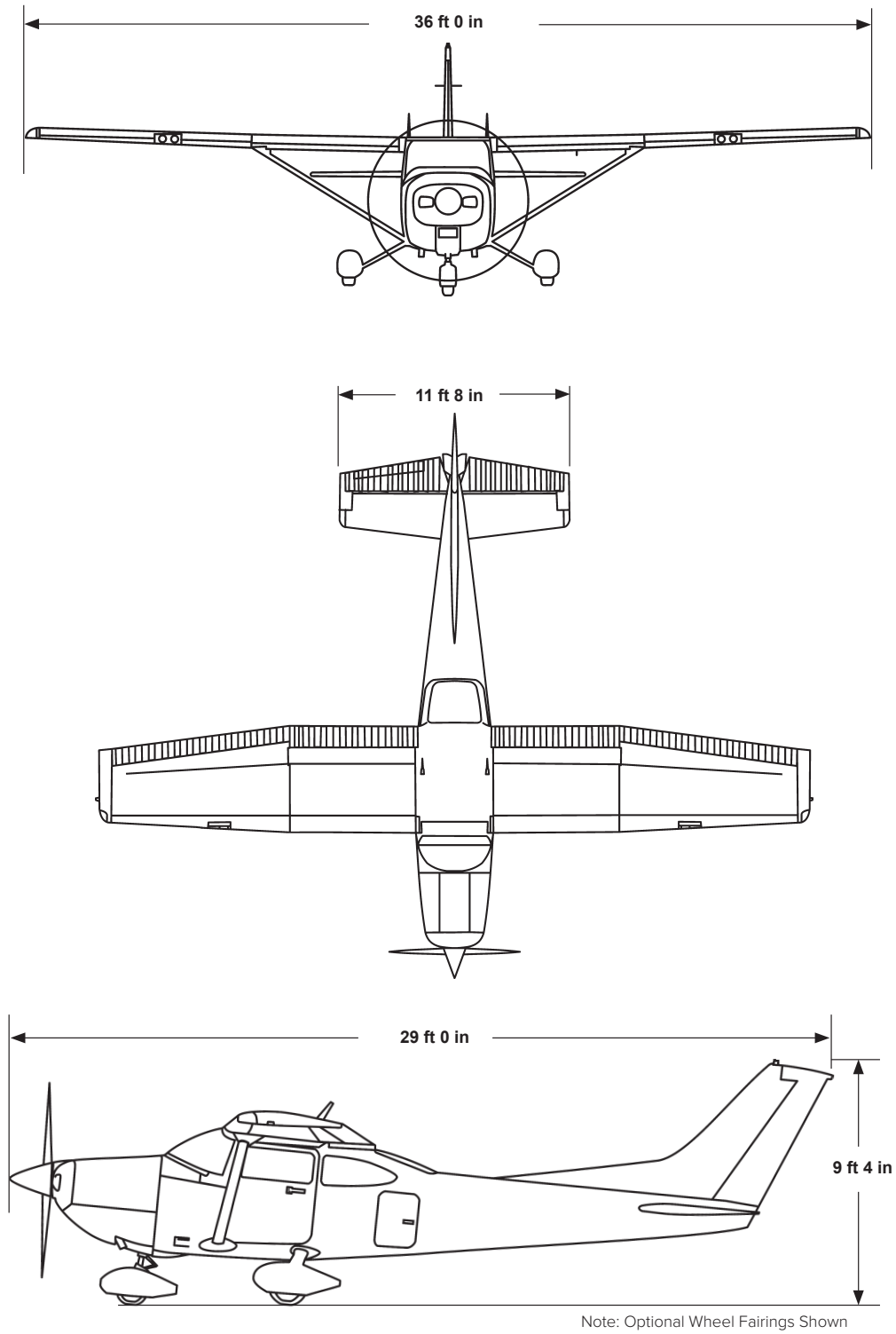
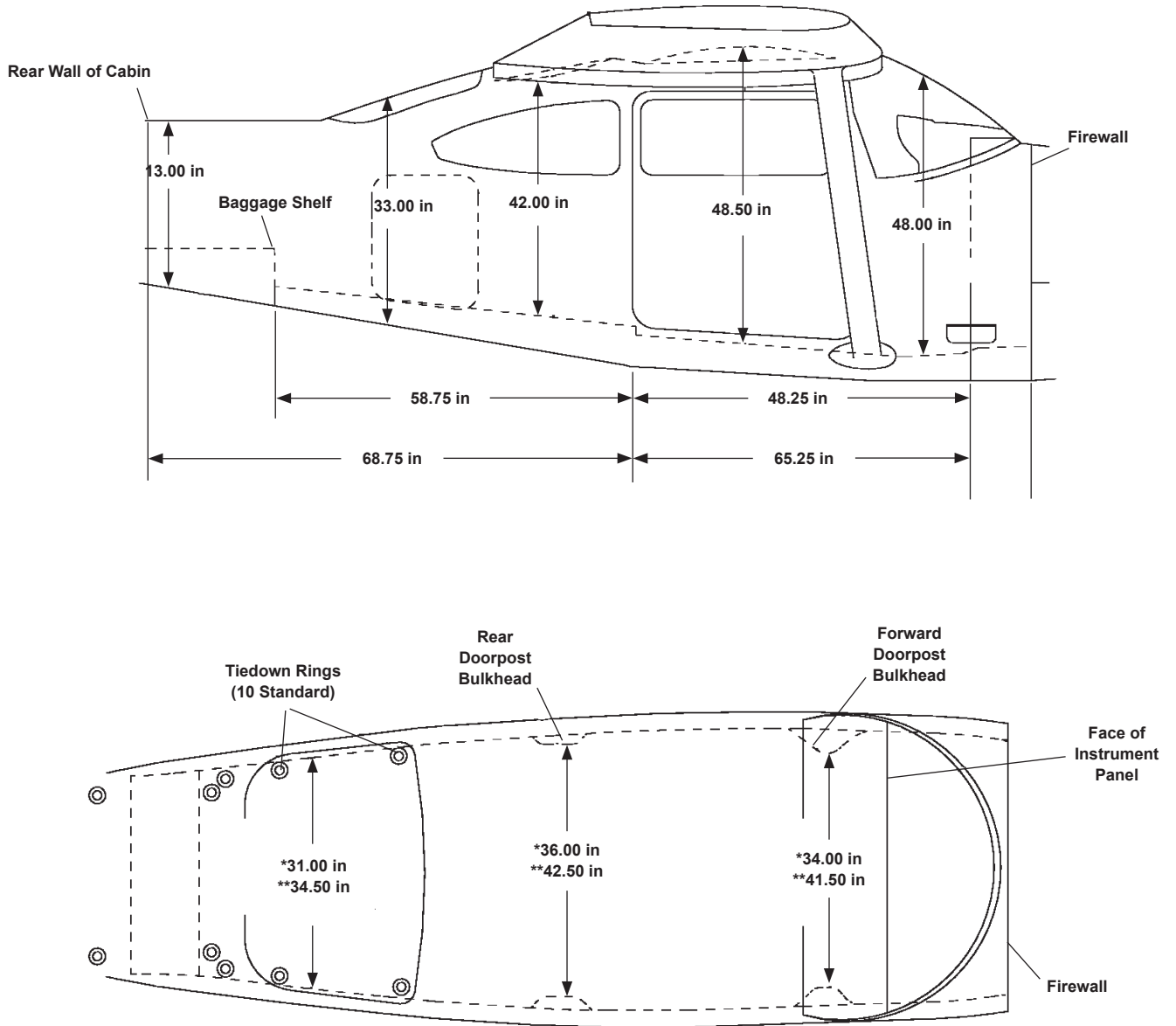

Figure 1: Exterior Dimensions

INTERIOR DIMENSIONS



Code
 *Cabin
 **Lower Window Line

Figure 2: Interior Dimensions

1.3 Approximate Dimensions

OVERALL HEIGHT	9 ft 4 in (2.84 m)
OVERALL WIDTH	36 ft 0 in (10.97 m)
OVERALL LENGTH	29 ft 0 in (8.84 m)
WHEELBASE	9 ft 0 in (2.74 m)

WING	SPAN (overall) 36 ft 0 in (10.97 m)	AREA 174 ft ² (16.17 m ²)	SWEEP (at 25% chord) 0°
HORIZONTAL TAIL	SPAN (overall) 11 ft 8 in (2.71 m)	AREA 35 ft ² (3.25 m ²)	(at 25% chord) 0°
VERTICAL TAIL	HEIGHT (overall) 9 ft 4 in (2.84 m)	AREA 19 ft ² (1.77 m ²)	(at 25% chord) 35°
CABIN INTERIOR (with typical interior)	HEIGHT (max) 49 in (1.23 m)	LENGTH* 11 ft 2 in (3.40 m)	WIDTH (max) 42 in (1.07 m)

*Cabin Length - Bulkhead to bulkhead

1.4 Design Weights and Capacities

MAXIMUM RAMP WEIGHT	3,110 lb (1,411 kg)
MAXIMUM TAKEOFF WEIGHT	3,100 lb (1,406 kg)
MAXIMUM LANDING WEIGHT	2,950 lb (1,338 kg)
BASIC EMPTY WEIGHT	1,995 lb (905 kg)
FUEL CAPACITY (usable at 6.0 lb/gal)	522 lb (237 kg)

2. PERFORMANCE

All performance data is based on a standard aircraft configuration, operating in International Standard Atmosphere (ISA) conditions with zero wind. Takeoff and landing lengths are based on a flat, even, hard surface at sea level with dry runway. Actual performance will vary with the individual aircraft and other factors such as environmental conditions, aircraft configuration, and operational/ATC procedures.

TAKEOFF DISTANCE OVER 50 FT OBSTACLE (Maximum Takeoff Weight)	1,514 ft (461 m)
TAKEOFF GROUND ROLL (Maximum Takeoff Weight)	795 ft (242 m)
MAXIMUM CERTIFIED ALTITUDE	18,100 ft (5,517 m)
MAXIMUM CRUISE SPEED (+/- 3%) (6,000 ft [1,829 m] altitude, Max. Cruise Power 25 In. Hg (or full throttle) @ 2,500 rpm)	145 KTAS (268 km/hr)
MAXIMUM FERRY RANGE (+/- 3%) (1 pilot, VFR. Range allows for taxi, take-off, climb, cruise, descent and VFR fuel reserve of 45 minutes at max. range power)	915 nm (1,695 km)
LANDING DISTANCE OVER 50 FT OBSTACLE (Maximum Landing Weight, Full flaps)	1,350 ft (411 m)
LANDING GROUND ROLL (Maximum Landing Weight)	590 ft (180 m)

3. DESIGN LIMITS

DESIGN LOAD LIMITS	
OPERATING LIMIT SPEEDS	
V_{NE} (Never Exceed V_{NE})	175 KIAS (324.1 km/hr)
V_{NO} (Max Structural Cruising V_{NO})	140 KIAS (259.2 km/hr)
V_A (Maneuvering V_A)	110 KIAS (203.7 km/hr)
FLAP LIMIT SPEEDS	
V_{FE} (Flaps 10°)	140 KIAS (259.3 km/hr)
V_{FE} (Flaps 10° to 20°)	120 KIAS (222.2 km/hr)
V_{FE} (Flaps 20° to Full)	100 KIAS (185.2 km/hr)

4. FUSELAGE

4.1 Design and Construction

The Skylane 182T incorporates a semi-monocoque fuselage of metallic construction with an internal cabin.

4.2 Nose Section

The nose section houses a single Lycoming IO-540-AB1A5 piston engine. This Aircraft is equipped with a one-piece plastic windshield and windshield defroster controlled through the main control knob.

4.3 Interior Spaces

The flight compartment and cabin are described in part 10 and 11 respectively.

4.4 Aft Fuselage

The aft fuselage contains an emergency locator transmitter.

5. WING

This Aircraft features a straight high wing design that is externally braced to the fuselage. The wings are constructed of front and rear spars with formed sheet metal ribs, doublers and stingers.

Flaps and frise-type ailerons are incorporated into each wing.

6. EMPENNAGE

The empennage features a conventional vertical and horizontal stabilizer configuration.

7. LANDING GEAR

7.1 Design and Construction

The landing gear is of the non-retracting, fixed tricycle type with a nosewheel and two main wheels.

7.2 Nosewheel Steering

The nose gear assembly is of conventional strut design. Nosewheel steering is mechanically actuated by the rudder pedals.

7.3 Brakes and Tires

Each main gear wheel is equipped with hydraulically actuated disc brakes.

The Skylane 182T is equipped with single wheels and tires. (three tires; one nose gear and one each left and right main).

	PLY	SIZE
NOSE GEAR TIRES	6	5.00 x 5
MAIN TIRES	6	6.00 x 6

8. PROPULSION

8.1 Powerplant

The Aircraft is powered by a single fuselage mounted Lycoming IO-540-AB1A5 piston engine.

The propulsion system is operated by the throttle lever in the flight deck.

TAKEOFF POWER (at sea level)	230 hp
TBO	2,000 Hours

8.2 Propeller

The engine is equipped with a metal McCauley 79-inch diameter, three blade constant speed propeller.

9. SYSTEMS

9.1 Flight Controls

The manually operated Primary Flight Controls (PFCs) are mechanically operated through a push rod and cable system. The PFCs consist of one aileron on each wing, one elevator on the horizontal tail and one rudder on the vertical tail.

9.2 Fuel System

The Skylane 182T features two vented integral wet wing fuel tanks, which allows fuel to flow using gravity through the fuel manifold to the engine. The fuel system also incorporates a fuel return system that returns fuel from the servo back to each integral tank.

The Skylane 182T is certified for grade 100LL (blue) and grade 100 (green) aviation gasoline.

Total useable fuel is 87 gal (329.3 L).

9.3 Electrical System

The Aircraft's 28-volt direct control electrical system is powered by a 95 amp belt driven alternator and main battery. The Aircraft's main battery is a 24-volt, 10.0 amp-hour manifold type battery, which is located forward of the firewall. The alternator and main battery are controlled through the MASTER switch on the instrument panel. Power is supplied to most general electrical and all avionics circuits through two general buses, two avionics buses and a battery bus.

In the event of an alternator and main battery failure a 24-volt, 6.2 amp-hour sealed type battery, located between the firewall and instrument panel will provide power to the essential bus

9.4 Exterior Lighting System

9.4.1 Primary

Standard exterior lighting consists of LED navigation lights on the wing tip and tail, dual wing LED landing/taxi lights integrated with pulse recognition technology, a LED ground recognition flashing beacon located on the vertical fin and a strobe anti-collision light on each wing tip.

9.4.2 Secondary

Secondary lighting includes two courtesy lights which are recessed into the lower surfaces of each wing and provide illumination for each cabin door area.

9.5 Environmental System

The environmental system consists of cabin heating and ventilation systems. Cabin ventilation and heat are provided by a muffler shroud and controlled by cabin air, cabin heat and aux cabin air knobs.

10. FLIGHT COMPARTMENT

10.1 General

The Garmin G1000 NXi system is the featured avionics suite on the Skylane 182T. Two full-color, 10-inch, high resolution flight displays are included.

10.2 Instrumentation



Figure 3: Instrumentation

1. MASTER SWITCH (ALT AND BAT)	11. Cabin Air, Defroster Controls
2. STBY BATT Switch	12. Wing Flap Control Lever and Position Indicator
3. STBY BATT Test Annunciator	13. Mixture Control Knob
4. AVIONICS Switch (BUS 1 and BUS 2)	14. Propeller Control Knob
5. Primary Flight Display	15. Throttle Control Knob (With Friction Lock)
6. Standby Airspeed, Attitude, Altimeter Indicators	16. Go-Around Button
7. Audio Control Panel	17. ALT Static Air Valve Control
8. Multifunction Display	18. Electrical Switch Panel
9. ELT Remote Switch/Annunciator	19. MAGNETOS/START Switch
10. Flight Hour Recorder	20. DIMMING Panel

10.3 Avionics

The Garmin G1000 NXi integrated avionics system includes the Garmin Integrated Flight Deck (GIFD), flight crew radio communications, navigation receivers, Engine Indicating System, Crew Alerting System, Flight Guidance System and Attitude/Heading Reference System.

10.3.1 Flight Displays

The GIFD includes two 10 inch, high-resolution Liquid Crystal Displays (LCD) in widescreen, landscape orientation. The left display is the Primary Flight Display. The Multi-Function Display is the right display.

10.3.1.1 Primary Flight Display (PFD)

The PFD is located on the pilot's instrument panel. The PFD displays flight information, moving map imagery, and color-coded Crew Alerting System messages.

10.3.1.2 Multi-Function Display (MFD)

The MFD, is located in the co-pilots instrument panel, displays a detailed moving map, terrain, traffic, and weather information as well as a dedicated engine and systems information window. Display of electronic charts and taxi diagrams are included.

Multiple reversionary modes provide for control redundancy.

Applicable subscription services are the Purchaser's responsibility.

10.3.2 Garmin's Integrated Avionics Unit (GIA)

Dual Integrated Avionics Units include the Global Positioning System with Wide Area Augmentation System (WAAS) receivers, Very High Frequency (VHF) communication radios, VHF navigation radios, and glideslope receivers in addition to supporting input-output processing, aural alert generation, and Flight Director functions.

10.3.2.1 Global Positioning System (GPS)

The G1000 NXi system includes dual GPS with WAAS receivers as part of the GIA.

10.3.2.2 Very High Frequency Radio (VHF)

The G1000 NXi system includes two standard VHF voice radios that are part of the GIA. The VHF voice radios are controlled by the flight crew via the audio panel controls.

10.3.2.3 Navigation Receivers

The G1000 NXi system includes two standard VHF navigation radios as part of the GIA.

10.3.3 Engine Indicating System (EIS)

The Engine Indicating System (EIS) displays electrical, fuel and engine information on the left side of the MFD.

10.3.4 Crew Alerting System (CAS)

The Crew Alerting System (CAS) displays Warning Messages (red), Caution (yellow), Advisories (white) on the PFD. The messages appear in the annunciation window which is to the right of the altimeter and vertical speed indicator.

10.3.5 Flight Guidance System (FGS)

The GFC-700 Automatic Flight Control System (AFCS) is part of the Garmin G1000 NXi. The AFCS can be divided into the following functions:

- Flight Director—The Flight Director provides vertical/lateral mode selection and processing, and command bars showing pitch/roll guidance.
- Autopilot—The autopilot provides automatic flight control in response to Flight Director steering commands and attitude and rate information.
- Automatic Pitch Trim—The pitch trim system provides automatic pitch trim when the autopilot is engaged.

10.3.6 Attitude/Heading Reference System (AHRS)

The Attitude/Heading Reference System (AHRS) includes two units that provide attitude and heading reference information.

10.3.7 Transponder with ADS-B In/Out Capability

The Garmin GTX 345R remote-mount transponder has 1090 MHz ADS-B “Out” and dual-link ADS-B “In”.

10.3.8 Emergency Locator Transmitter (ELT)

The Artex ME-406 2-frequency (non-navigation interfaced) Emergency Locator Transmitter (ELT) consists of the ELT transmitter located in the aft fuselage area, an antenna mounted on the aft fuselage and a remote switch with a red transmit light located on the instrument panel.

10.3.9 Standby Instrumentation

A standby attitude indicator is located in the center of the instrument panel. It is connected to the airplane's engine driven vacuum system and is independent of the airplane's electrical system.

A standby mechanical airspeed indicator is mounted in the center of the instrument panel. The indicator is connected to the airplane's pitot and static systems along with the Air Data Computer. The airspeed indicator remains operational in the event of complete electrical failure and will also operate with the alternate static source.

A standby mechanical altimeter is located in the center of the instrument panel. It is connected to the airplane's normal and alternate static systems along with the Air Data Computer and is independent of the airplane's electrical system except for lighting.

A standby self-contained, non-stabilized magnetic compass is located in the center of the windshield.

During the normal course of aircraft manufacturing, maintenance, and operation, technicians install or update certain software and data onto standard and optional avionics and other equipment. During the course of such installation, it may be necessary to digitally "accept" or otherwise consent to certain supplier required end-user license agreements ("EULA") and other terms and conditions in order to proceed with the software or data installation process. These are commonly referred to as "click-wrap" or "click-through" digital agreements. Purchaser hereby authorizes and consents to technicians clicking "accept" on such agreements and agrees to be bound by the terms of such agreements. Purchaser acknowledges and agrees that it will independently review such "click-wrap" agreements.

11. INTERIOR

11.1 Cabin

Entry to, and exit from the airplane is accomplished through two entry doors, one on each side of the cabin at the front seat positions. A lockable door on the left side of the airplane provides external access to the interior baggage compartment behind the rear seats. The cabin extends from the cockpit to the rear baggage area and provides a cabin height of 49 inches (1.25m). Emergency egress is provided through cabin doors.

The Skylane 182T offers a four-seat configuration with ergonomically designed seats wrapped in Luxor 2 Leather.

The following are included in the typical arrangement:

- Two vertically adjusting crew seats for the pilot and front passenger, and an adjustable split bench seat for rear seat passengers, where each passenger can adjust their seat angles.
- Each seat is equipped with Amsafe inflatable seat belts and shoulder harness assemblies..
- Six adjustable air vents throughout the cabin, four located in the cockpit and two located in the passenger area.
- Two cup holders located in the cockpit and two in the aft of the Aircraft.

Certified burn-resistant materials are used throughout the cabin.



Figure 4: Typical Configuration

11.2 Entertainment System

Fore and aft built-in 12-volt cabin power ports allow passengers to work or be entertained for the duration of the flight.

11.3 Windows

Five tinted windows are installed in the cabin: an openable window on the left and right pilot and copilot doors, two fixed passenger windows and an additional fixed rear window.

11.4 Interior Lighting System

Interior lighting includes LED backlit instrument panel lighting, two overhead reading lights and two flood lights located in the cockpit ceiling. There are also two overhead reading lights located in the rear ceiling of the passenger cabin.

11.5 Interior Storage

An interior baggage compartment, which allows for convenient in flight access, is located behind the rear seats. The baggage compartment is also accessible through the exterior baggage door on the right side of the fuselage.

	WEIGHT	VOLUME
INTERIOR BAGGAGE AREA	200 lb. (91 kg)	32 ft ³ (.91 m ³)

12. EXTERIOR

Distinctive exterior styling featuring polyurethane paint in a variety of colors is provided.

The available registration number of Purchaser's choice will be applied on the Aircraft with a glossy black vinyl at no additional cost to Purchaser. It may be necessary to use a temporary registration number until the number selected by Purchaser is assigned to the Aircraft by the appropriate aviation authority.

13. LOOSE EQUIPMENT

Baggage Net (Black [1])

Cessna Logo - Fuel Jar (1)

Console Assembly with GATS (1)

Control Lock Assembly (1)

GATS Fuel Cup (1)

Pitot Tube Bootie (1)

Tow Bar Assembly (1)

14. EMERGENCY EQUIPMENT

Fire Extinguisher (1)

15. DOCUMENTATION AND TECHNICAL PUBLICATIONS

The following will be provided to Purchaser.

Print material:

The following must be kept on board the Aircraft

Abbreviated Aircraft Checklist

Aircraft Weight and Balance

Garmin Cockpit Reference Guide

Passenger Briefing Cards (4)

Pilot Operating Handbook (POH)

U.S. Standard Airworthiness Certificate, FAA8100-2: Export Certification of Airworthiness, FAA8130-4 or Special Airworthiness Certificate FAA8130-7 as appropriate.

Additional print material:

AOS Printout

Conformity Letters

Garmin Pilot's Guide

Garmin Serial Number List

Logbooks (Airframe, engine)

Lycoming Engine Information Packet

McCauley Propeller Logbook

Available on CD-ROM or accessible from www.txtavsupport.com:

Illustrated Parts Catalog

Maintenance Manual

Service Bulletins and Service Letters

Structural Repair Manual

Wiring Diagram Manual

Documents providing instructions for continued airworthiness are provided via www.txtavsupport.com.

Available post-delivery:

Seller will provide technical manual revisions for documents published by Seller for five years beginning on the start date of airframe warranty.

Some post-delivery documents are fee-based and are the Purchaser's responsibility.

16. LIMITED WARRANTIES

The Seller's Skylane 182T Limited Aircraft Warranty (Limited Aircraft Warranty) covers the Aircraft airframe and parts manufactured by Textron Aviation Inc. (this excludes the propeller which is warranted by Seller under a separate limited propeller warranty), incorporated Garmin Avionics, Vendor Parts (except the engine), Interior Furnishings and Paint. The Aircraft engine is warranted by Lycoming Engines, a division of Avco Corporation (Lycoming). The Limited Aircraft Warranty and summaries of the limited propeller warranty and the Lycoming engine warranty are set out below.

16.1 Limited Aircraft Warranty

Periods

The Seller warrants each new Skylane 182T Aircraft to be free from defect in material and workmanship for the following periods after delivery of the Aircraft to Purchaser:

- (a) Two years or 1000 operating hours, whichever occurs first, for Aircraft airframe and parts manufactured by Textron Aviation Inc.;

- (b) Two years for Garmin Avionics hardware;
- (c) Two years or 1000 operating hours, whichever occurs first, for Vendor Parts (except the engine);
- (d) One year for Interior Furnishings and Paint.

Any remaining term of this Limited Aircraft Warranty automatically transfers to subsequent purchasers of the Aircraft.

Definitions

Support Facility means Textron Aviation Parts Distribution, Textron Aviation-owned service facilities, and service facilities authorized by Textron Aviation to perform warranty service on the Aircraft.

Service Facility means Textron Aviation-owned service facilities and service facilities authorized by Textron Aviation to perform warranty service on the Aircraft.

Warranty Holder means Aircraft owner.

Seller's Obligation

Parts

Seller's obligation under this Limited Aircraft Warranty is limited to repairing the defective part or replacing the defective part with an exchange part, in Seller's sole discretion, when:

- (a) the failure occurs within the applicable warranty period;
- (b) all of the following occur within 30 days of failure for a U.S. Warranty Holder and 45 days of failure for an international Warranty Holder:
 - (i) a claim is made and a Textron Aviation Return Authorization is issued;
 - (ii) the part is returned at the Warranty's Holders expense to the Support Facility from where the replacement part is procured; and
 - (iii) the return part is accompanied by the Textron Aviation issued Return Authorization; and
- (c) the Support Facility identifies the part and determines the part is defective.

The Seller may refuse a warranty claim not submitted within the above time frame.

Replacement parts are only warranted for the remainder of the applicable, original Limited Aircraft Warranty period. In other words, a new warranty period is not established for replacement parts.

No Aircraft part or equipment will be regarded as breaching this Limited Aircraft Warranty merely because, subsequent to its delivery, some modification or alternation becomes necessary for product improvements or in order to meet a change in the requirements of applicable Federal Aviation Regulations.

Service

Service under this Limited Aircraft Warranty must be performed at a Service Facility. The Warranty Holder will not be charged for parts or labor covered by this Limited Aircraft Warranty. The location of Service Facilities is available on the Seller's website.

Warranty Holder's Responsibility

All freight, transportation expenses, import duties, customs brokerage fees, sales taxes and use taxes, if any, on warranty repairs or replacement parts are the Warranty Holder's sole responsibility. The Warranty Holder is responsible for the cost of getting the Aircraft to and from a Service Facility.

Application

This Limited Aircraft Warranty applies to Aircraft operated under normal, conventional, non-military use. It applies only to the repair or replacement of defective parts that have been used, maintained, and operated in accordance with the Federal Aviation regulations and the applicable manuals, bulletins, communications, or other written instructions of the Aircraft or component manufacturers.

Limitations

This Limited Aircraft Warranty does not apply to:

- (a) normal maintenance services (such as engine adjustments, cleaning, control rigging, brake and other mechanical adjustments, and maintenance inspections);
- (b) the replacement of service items (such as brakes, lights/bulbs, filters, de-ice boots, hoses, belts, tires, batteries, rubber-like items, fuel or lubricants);
- (c) normal deterioration of appurtenances (such as paint, cabinetry, and upholstery);
- (d) damage due to wear, exposure, environmental elements, and neglect;

(e) parts, components or systems that have been modified or altered after delivery other than by the Aircraft manufacturer or in accordance with an alternation scheme approved in writing by Textron Aviation;

(f) items that have been subjected to misuse, abuse, negligence, accident, foreign object damage (FOD);

(g) items that have been installed, repaired, or altered by repair facilities not authorized by Textron Aviation;

(h) items that, in Textron Aviation's sole discretion, have been installed, repaired, or altered by other than Textron Aviation-owned service facilities contrary to applicable manuals, bulletins, and other written instructions provided by Textron Aviation so that the performance, stability, or reliability of such items are adversely affected;

(i) any part or system that has been modified or altered by a third party at the Warranty Holder or its predecessor's request and any part or system of the Aircraft affected by such modified or altered part or system;

(j) vendor subscription services (including for items covered by the Limited Aircraft Warranty), software and databases (collectively "Services"), and patches, replacements, revisions, updates or upgrades thereto (collectively "Updates") and any impairment to the Aircraft or its components caused by Services or Updates.; and

(k) Warranty Holder or predecessor's furnished equipment.

The warranty provided for life-limited parts is pro-rated. For Aircraft components, parts, or systems with life limitations Seller's liability under this Limited Aircraft Warranty is limited to the remaining pro-rated life of the defective part, calculated as of the date the defect is discovered and reported to Seller and per additional terms administered by Textron Aviation's Warranty Department. Nothing about this provision will be construed to extend the total warranty period beyond the applicable Periods set out above. All warranty Periods expires as noted above, regardless of any remaining life limits on parts.

WITH THE EXCEPTION OF THE WARRANTY OF TITLE AND TO THE EXTENT ALLOWED BY APPLICABLE LAW, THIS LIMITED AIRCRAFT WARRANTY IS EXPRESSLY IN LIEU OF ANY OTHER WARRANTIES, EXPRESSED OR IMPLIED, IN FACT OR BY LAW, APPLICABLE TO THE AIRCRAFT. THERE ARE NO WARRANTIES WHICH EXTEND BEYOND THE DESCRIPTION ON THE FACE HEREOF. SELLER SPECIFICALLY DISCLAIMS AND EXCLUDES ALL OTHER WARRANTIES, INCLUDING, BUT NOT LIMITED TO, ANY IMPLIED WARRANTY OF MERCHANTABILITY OR FITNESS FOR A PARTICULAR PURPOSE. THE REMEDIES

OF REPAIR OR REPLACEMENT OF THE DEFECTIVE PART(S) AS SET OUT HEREIN ARE THE ONLY REMEDIES UNDER THIS LIMITED AIRCRAFT WARRANTY. SELLER EXPRESSLY AND SPECIFICALLY DISCLAIMS ALL OTHER REMEDIES, OBLIGATIONS, AND LIABILITIES, INCLUDING, BUT NOT LIMITED TO, LOSS OF AIRCRAFT USE, LOSS OF TIME, INCONVENIENCE, COMMERCIAL LOSS, LOSS OF PROFITS, LOSS OF GOODWILL, DIMINUTION OF MARKET VALUE, AND ANY AND ALL OTHER CONSEQUENTIAL, INDIRECT, INCIDENTAL, SPECIAL, MULTIPLE OR PUNITIVE DAMAGES, OR ANY DAMAGES TO THE AIRCRAFT CLAIMED BY PURCHASER OR ANY OTHER PERSON OR ENTITY UPON THE THEORIES OF NEGLIGENCE OR STRICT LIABILITY IN TORT. SELLER NEITHER ASSUMES NOR AUTHORIZES ANYONE ELSE TO ASSUME ON ITS BEHALF ANY FURTHER OBLIGATIONS OR LIABILITY PERTAINING TO THE AIRCRAFT NOT CONTAINED IN THIS LIMITED AIRCRAFT WARRANTY.

THIS LIMITED AIRCRAFT WARRANTY WILL BE CONSTRUED UNDER THE LAWS OF THE STATE OF KANSAS AND ANY DISPUTES AND/OR CLAIMS ARISING THEREFROM WILL BE EXCLUSIVELY RESOLVED IN THE STATE AND/OR FEDERAL COURTS LOCATED IN WICHITA, KANSAS. THE PARTIES CONSENT TO PERSONAL JURISDICTION IN THE FORUM CHOSEN AND WAIVE THEIR RIGHT TO JURY TRIAL. ANY ACTION BY PURCHASER FOR BREACH OF THIS WARRANTY MUST BE COMMENCED WITHIN ONE (1) YEAR AFTER THE CAUSE OF ACTION ACCRUES. THE CAUSE OF ACTION ACCRUES WHEN THE PURCHASER FIRST LEARNS THAT THE WARRANTY HAS BEEN BREACHED.

16.2 Summary of Seller's Limited Propeller Warranty

Seller expressly warrants new products produced and sold by McCauley Propeller Systems (McCauley), a Division of Textron Aviation Inc., Wichita, Kansas, U.S., to be free from defects in material and workmanship under normal use and service for a period of thirty-six (36) months after delivery to the original retail purchaser or until the expiration of the maximum hours of use or calendar limits for overhaul published by McCauley for the subject product, whichever occurs first.

Seller's obligation under this limited warranty is limited to repairing or replacing, at its sole option, any propeller, propeller parts, governor or governor parts determined by McCauley to have been defective. The repair or replacement of defective parts will be made without charge to the owner for parts, or labor for removal and installation, except export/import duties, and/or sales or use taxes, if any, which are solely the owner's responsibility. Seller will warrant a part replaced pursuant to this limited warranty under the same terms as the original part for the remainder of the applicable warranty period of the original part. This limited warranty is not intended to and does not cover the costs of normal maintenance or overhaul. In addition, McCauley will repair or replace, at its option,

any propeller, propeller parts, governor, or governor parts requiring replacement due to manufacturing defect if found at or before the first recommended overhaul interval as described in McCauley published service information. This first overhaul coverage does not include labor, standard overhaul replacement parts, parts repairable via published service information (re-plating, painting, etc.), other costs associated with the propeller or governor overhaul, or export/import duties, and/or sales or use taxes, nor does it apply to defects found after McCauley published overhaul hour or calendar limits. The provisions of this limited warranty do not apply to: any McCauley parts which have been subject to misuse, negligence or accident or which have been repaired or altered in any way that, in the sole judgment of McCauley, adversely affects their performance, stability or reliability; to normal maintenance services (such as cleaning, mechanical adjustments and maintenance inspections); to the replacement of service items made in connection with normal maintenance; to normal deterioration of soft trim and appearance items (such as paint and rubber-like items) due to wear and exposure; to propellers, governors or parts found defective beyond the McCauley recommended overhaul period; or to parts which have been improperly installed by entities other than Seller or service facilities authorized by Seller to perform maintenance on McCauley propellers.

The propeller limited warranty is void on any new or remanufactured product installed, without McCauley's prior written approval, on a non-type certificated engine, or on any engine which has received an overhaul or modification which is not approved by the engine manufacturer and that results in a change to the vibratory environment of the engine such as, but not limited to, an alteration of horsepower, operating RPM, crankshaft damper configuration, compression ratio, magneto timing, camshaft design, or any other overhaul or modification not expressly approved by the original engine manufacturer. This limited propeller warranty is also void on any McCauley product shipped new from the factory or distributor in disassembled state, then later re-assembled by an unauthorized party. Parties authorized to install factory-new product must have specific written permission from McCauley to do so, otherwise the propeller limited warranty on the affected unit is void.

No Seller warranty coverage is offered for leakage on product installed outside McCauley, regardless of the assembling party.

To the extent allowed by applicable law, THIS WARRANTY IS EXPRESSLY IN LIEU OF ANY OTHER WARRANTIES, EXPRESSED OR IMPLIED IN FACT OR BY LAW, INCLUDING ANY IMPLIED WARRANTY OF MERCHANTABILITY OR FITNESS FOR A PARTICULAR PURPOSE. THE REMEDIES OF REPAIR OR REPLACEMENT SET FORTH HEREIN ARE THE ONLY REMEDIES UNDER THIS WARRANTY. SELLER DISCLAIMS ANY OBLIGATION OR LIABILITY, WHETHER IN CONTRACT OR IN TORT, INCLUDING LOSS OF USE OF THE PRODUCT WARRANTED, LOSS OF TIME, INCONVENIENCE, LOSS OF PROFITS, COMMERCIAL LOSS OR ANY

OTHER DIRECT, CONSEQUENTIAL, SPECIAL OR INCIDENTAL DAMAGES. THIS WARRANTY IS IN LIEU OF ANY OBLIGATION OR LIABILITY ON THE PART OF SELLER TO ANYONE OF ANY NATURE WHATSOEVER BY REASON OF THE MANUFACTURE, SALE, LEASE OR USE OF THE WARRANTED PRODUCTS AND SELLER NEITHER ASSUMES NOR AUTHORIZES ANYONE TO ASSUME FOR IT ANY OTHER OBLIGATION OR LIABILITY IN CONNECTION WITH SUCH WARRANTED PRODUCTS.

Details of this warranty are available from Seller.

16.3 Summary of Lycoming Engine Warranty

NEW AND REBUILT RECIPROCATING AIRCRAFT ENGINES:

(1) WARRANTY: Lycoming Engines, a division of Avco Corporation (hereinafter "Lycoming") warrants each new and rebuilt Lycoming reciprocating engine to be free from defect in material or workmanship under normal use and service for a period of twenty-four (24) months or the recommended engine time (hours) between overhauls ("TBO") in accordance with the latest edition of Lycoming Service Instruction 1009, whichever occurs first. Lycoming's sole obligation under this warranty is limited to replacement or repair of parts which are determined by Lycoming to have been defective within the warranty period. The warranty period commences on: (a) the date of first operation after new aircraft delivery to the original retail purchaser or first user; or (b) twenty-four (24) months from the engine ship date from Lycoming, whichever occurs first.

(2) HIGHLY UTILIZED ENGINES / LYCOMING LOYALTY PROGRAM WARRANTY: Additionally, Lycoming also warrants the crankcase, crankshaft, cylinders*, sump, accessory housing and all internally lubricated parts to be free from defects in material or workmanship under normal use and service for an additional twelve (12) month period from the warranty period applicable in (1) above on highly utilized engines that consistently accumulate forty (40) or more flight hours per month. This additional twelve (12) month warranty period is limited to new or rebuilt engines purchased on an exchange basis in accordance with a Lycoming Loyalty program through an Authorized Lycoming distributor.

(3) REMEDY: Within the warranty period, Lycoming may reimburse the purchaser for (a) parts; (b) prorated engine replacement; (c) labor; and (d) freight associated with warranty related issues.

(3)(a): Warranty replacement parts installed on engines which are covered by this New and Rebuilt Engine Warranty will be warranted for the balance of the original engine warranty period. At Lycoming's sole discretion, warranty replacement parts may be either new or reconditioned. A claim for warranty must be reported

in writing to an Authorized Lycoming distributor within 30 days of any suspected defect in material or workmanship. Warranty is contingent upon the purchaser complying with the Lycoming Warranty Administration disposition instructions for all parts being returned for warranty evaluation. Lycoming Warranty Administration may require the return of additional components, documents or photographs necessary to evaluate a warranty claim. Failure to comply with all of the terms of this paragraph (3)(a) may, at Lycoming's sole option, void this warranty.

(3)(b): At Lycoming's sole option, Lycoming may elect, on a prorated exchange basis, to replace rather than repair an engine. Warranty reimbursement for a prorated replacement engine will be calculated based on the documented time (hours) on the engine, the recommended engine time (hours) between overhauls ("TBO") in accordance with the latest edition of Lycoming Service Instruction 1009 and the then current published engine list price.

Warranty reimbursement for labor charges in connection with a prorated exchange engine replacement will be calculated based on the documented time (hours) on the engine, the recommended engine time (hours) between overhauls ("TBO") in accordance with the latest edition of Lycoming Service Instruction 1009 and Lycoming's then current Removal and Installation Labor and Allowance Guidebook.

(3)(c): Lycoming will only reimburse the cost of such labor charges in connection with repair or replacement of parts as provided in Lycoming's then current Removal and Installation Labor and Allowance Guidebook.

(3)(d): Lycoming will, in connection with the foregoing warranty, reimburse standard freight charges with respect to any such approved warranty replacement or repair. The use of expedited freight must be pre-approved by Lycoming.

(4) THIS WARRANTY IS GIVEN AND ACCEPTED IN PLACE OF (i) ALL OTHER WARRANTIES OR CONDITIONS, EXPRESS OR IMPLIED, INCLUDING BUT NOT LIMITED TO THE IMPLIED WARRANTIES OR CONDITION OF MERCHANTABILITY AND FITNESS FOR A PARTICULAR PURPOSE AND (ii) ANY OBLIGATION, LIABILITY, RIGHT, CLAIM OR REMEDY IN CONTRACT OR IN TORT (DELICT), INCLUDING PRODUCT LIABILITIES BASED UPON STRICT LIABILITY, NEGLIGENCE, OR IMPLIED WARRANTY IN LAW AND PURCHASER HEREBY WAIVES SUCH RIGHTS AND CLAIMS.

(5) THIS WARRANTY IS THE ONLY WARRANTY MADE BY LYCOMING. THE PURCHASER'S SOLE REMEDY FOR A BREACH OF THIS WARRANTY OR ANY DEFECT IN A PART IS THE REPAIR OR REPLACEMENT OF ENGINE PARTS AND REIMBURSEMENT OF REASONABLE FREIGHT CHARGES AS PROVIDED HEREIN. LYCOMING DISCLAIMS LIABILITY, WHETHER AS A RESULT OF A BREACH OF CONSEQUENTIAL DAMAGES, INCLUDING, BUT NOT LIMITED TO, DAMAGE TO

THE ENGINE OR OTHER PROPERTY (INCLUDING THE AIRCRAFT IN WHICH THE ENGINE IS INSTALLED), COSTS AND EXPENSES RESULTING FROM REQUIRED CHANGES OR MODIFICATIONS TO ENGINE COMPONENTS AND ASSEMBLIES, CHANGES IN RETIREMENT LIVES AND OVERHAUL PERIODS, LOCAL CUSTOMS FEES AND TAXES, AND COSTS OR EXPENSES FOR COMMERCIAL LOSSES OR LOST PROFITS DUE TO LOSS OF USE OR GROUNDING OF THE AIRCRAFT IN WHICH THE ENGINE IS INSTALLED OR OTHERWISE. LYCOMING'S TOTAL LIABILITY FOR ANY AND ALL CLAIMS RELATED TO ANY ENGINE SHALL IN NO CASE EXCEED THE ORIGINAL SALES PRICE OF THE ENGINE. SELLER MAKES NO WARRANTY AND DISCLAIMS ALL LIABILITY WITH RESPECT TO COMPONENTS OR PARTS DAMAGED BY, OR WORN DUE TO, CORROSION.

(6) This warranty shall not apply to any engine or part thereof which has been repaired or altered outside Lycoming's factory in any way so as, in Lycoming's sole judgment, to affect its durability, safety or reliability, or which has been subject to misuse, negligence or accident. Repairs and alterations which use or incorporate parts and components other than genuine Lycoming parts or parts approved by Lycoming for direct acquisition from sources other than Lycoming itself are not warranted by Lycoming, and this warranty shall be void to the extent that such repairs and alterations, in Lycoming's sole judgment, affect the durability, safety or reliability of the engine or any part thereof, or damage genuine Lycoming or Lycoming-approved parts. No person, corporation or organization, including distributors of Lycoming engines, is authorized by Lycoming to assume for it any other liability in connection with the sale of its engines or parts, nor to make any warranties beyond the foregoing warranty nor to change any of the terms hereof. NO STATEMENT, WHETHER WRITTEN OR ORAL, MADE BY ANY PERSON, CORPORATION OR ORGANIZATION, INCLUDING DISTRIBUTORS OF LYCOMING ENGINES, MAY BE TAKEN AS A WARRANTY NOR WILL IT BIND LYCOMING. NO AGREEMENT VARYING THE TERMS OF THIS WARRANTY OR LYCOMING'S OBLIGATIONS UNDER IT IS BINDING UPON LYCOMING UNLESS IN WRITING AND SIGNED BY A DULY AUTHORIZED REPRESENTATIVE OF LYCOMING.

(7) All legal actions based upon claims or disputes pertaining to or involving this warranty including, but not limited to, Lycoming's denial of any claim or portion thereof under this warranty, must be filed in the courts of general jurisdiction of Lycoming County, Commonwealth of Pennsylvania or in the United States District Court for the Middle District of Pennsylvania located in Williamsport, Pennsylvania. In the event that purchaser files such an action in either of the court systems identified above, and a final judgment in Lycoming's favor is rendered by such court, then purchaser shall indemnify Lycoming for all costs, expenses and attorneys' fee incurred by Lycoming in defense of such claims. In the event purchaser files such a legal action in a court other than those specified, and Lycoming successfully obtains dismissal of that action or transfer thereof to the above described court systems, then purchaser shall indemnify Lycoming for

all costs, expenses and attorneys' fees incurred by Lycoming in obtaining such dismissal or transfer.

(8) Any invalidity of a provision of this Warranty shall not affect any other provision, and in the event of a judicial finding of such invalidity, this Agreement shall remain in force in all other respects.

*Excludes O-235 series cylinders.

Effective November 2013 Revision "P"

Lycoming Engines
652 Oliver Street
Williamsport, Pennsylvania
17701
(570) 323-6181
www.lycoming.com

17. FAMILIARIZATION TRAINING AGREEMENT

Seller will provide to Purchaser, as part of the Total Purchase Price for the Aircraft, a training package consisting of a familiarization training program for one (1) pilot subject to the following terms:

1. The familiarization training will be conducted by Textron Aviation Pilot Training (TAPT) located in Wichita, Kansas or at another TAPT training location determined by Seller.
2. TAPT will employ its standard established familiarization training curriculum which is reasonably calculated to result in a Factory Training Course Certificate and Record of Training. The curriculum consists of two and one-half (2.5) days of ground school and flight familiarization. Flights will be conducted in Purchaser's Aircraft or equivalent aircraft provided by Seller. If additional ground and/or flight familiarization is requested beyond the established course syllabus, the schedule, number of flight hours, and other details will be mutually agreed upon between Purchaser and TAPT at that time. All associated expenses for additional ground and/or flight familiarization will be Purchaser's responsibility.
3. Seller and TAPT cannot guarantee or otherwise assure successful completion of familiarization training, or ultimate qualification for any license, certificate, or rating. Neither Seller nor TAPT will be responsible for the competency of Purchaser's pilot(s) during and/or following familiarization training. Neither Seller nor TAPT assumes any responsibility or liability for training delay or incompleteness due to

factors beyond their control. To complete the in-aircraft portion of the familiarization training the trainee must be proficient in English.

4. All training must be completed within, and no later than, twelve (12) months following the delivery date of the Aircraft. No credit or any other financial adjustment will be allowed for any training not completed within the twelve (12) month period. TAPT will schedule all training, provide Purchaser specific details regarding the familiarization training course, course requirements, and completion options, and endeavor to schedule training at a time convenient for Purchaser.

5. Purchaser will be responsible for all expenses incurred by the individual taking training, including, but not limited to: food, lodging, transportation, car rental, and all costs of operating, maintaining, and insuring its Aircraft if used for training. Purchaser will also be responsible for all costs involved in acquiring an interpreter (for the ground school portion of the familiarization training) if the individual taking training is not proficient in English.

6. Purchaser and trainee hereby release and will indemnify and save harmless Seller and TAPT, their respective officers, employees, agents, subcontractors, and insurers (collectively Indemnified Parties) against any and from all liability, claims, actions, and causes of action whatsoever, including any claims for damage to the Aircraft, regardless of the cause thereof (excluding however, any liability or claim relating to the manufacture of the Aircraft and the negligence or willful misconduct of the Indemnified Parties) and all expenses in connection therewith (including reasonable attorney's fees) arising directly or indirectly out of or in connection with use of the Aircraft for the familiarization training described above.

Purchaser's execution of Aircraft Purchase Agreement constitutes Purchaser's acceptance of the foregoing terms and conditions.

Additional training to satisfy certification and/or operational requirements of Purchaser's cognizant Civil Aviation Authority (CAA) is outside the scope of the familiarization training provided by TAPT described above.



U.S. +1.844.44.TXTAV | INTERNATIONAL +1.316.517.8270 | TXTAV.COM

© 2018 **Textron Aviation Inc.** All rights reserved. Product names, company names, trademarks, service marks, trade names, trademark designs and logos of Textron Aviation Inc. or its subsidiaries (collectively "Marks"), whether or not appearing in large print, italics, or with trade marking symbols, are Marks of Textron Aviation Inc. or an affiliate and may be registered in the United States. Third party marks whether or not appearing in large print, italics, or with trade marking symbols are marks of others.

July 2018
S&D-PISTON-182T-0518